

Shining a Light on Solar:

Solar 101 for your home

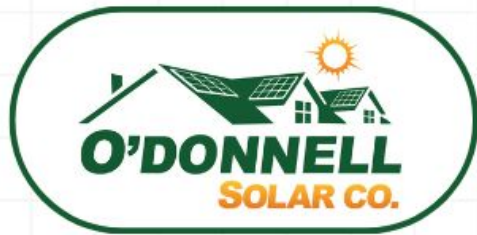

In partnership with Marple Library

April 2026

Solar 101: Overview

Topics of Discussion:

- Industry Overview
- Cost & Benefits
- Solar Home Design & Modeling
- Installation Breakdown & Safety
- Maintenance
- Home Batteries



Solar Industry

The way we generate, store, distribute and consume energy will be completely different in a decade.

It's not "IF" but "WHEN" and "HOW" ...

We believe that the future of energy will be a mix of centralized and distributed generation which utilizes many energy resources (solar, batteries, EVs and demand response) in concert with one another to provide energy to homes and businesses.

Environmental Impact of Solar

Generating your own solar energy on site reduces the amount of electricity purchased from utilities, which is primarily generated by centralized natural gas-fired power plants.

Energy transmission losses ([5% on average per the US EIA](#)) are avoided.

MAKE A POSITIVE IMPACT ON THE ENVIRONMENT

The amount of clean energy you generate in each year compared to purchasing energy from your utility would be equivalent to:



Driving
24,750 fewer miles



Growing
6,410 tree seedlings
for 10 years



Taking
2 passenger cars
off the road per
year

Solar Cost and Benefits – Example 1

Based on energy generation + [EPA greenhouse gas equivalencies calculator](#)

Solar Cost and Benefits

Solar is an investment in an asset that reliably generates clean energy for 25 years or more.

As electricity prices rise, so too does the value of electricity generated by solar.

⚡ PECO Electricity Price Trend (Approx. \$/kWh)

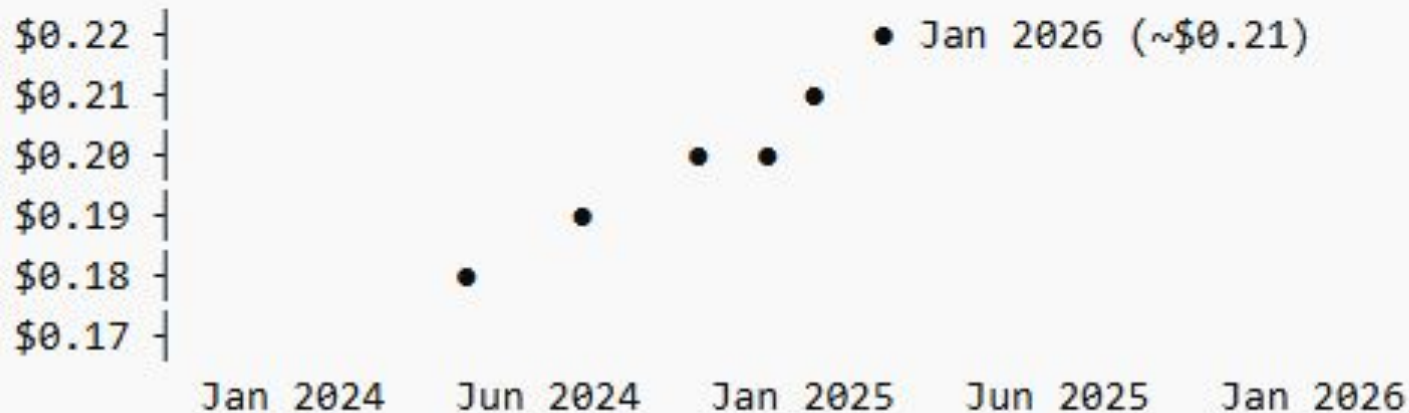

The trajectory of the recent increases in electricity cost is historically unusual.

Over 20 years, the typical average increase in electricity cost is closer to 2%, BUT many signs point to electricity cost continuing to increase at a higher rate.

Financial Modeling

- Financial models are based primarily on savings from the avoided cost of electricity
- Assumptions on future cost of electricity are most significant (*we use 2% - others may use a different assumption*)
- Also factors in Solar Renewal Energy Credits (SREC)
- Loan financing utilizes savings + terms of loan repayment (rate and length)

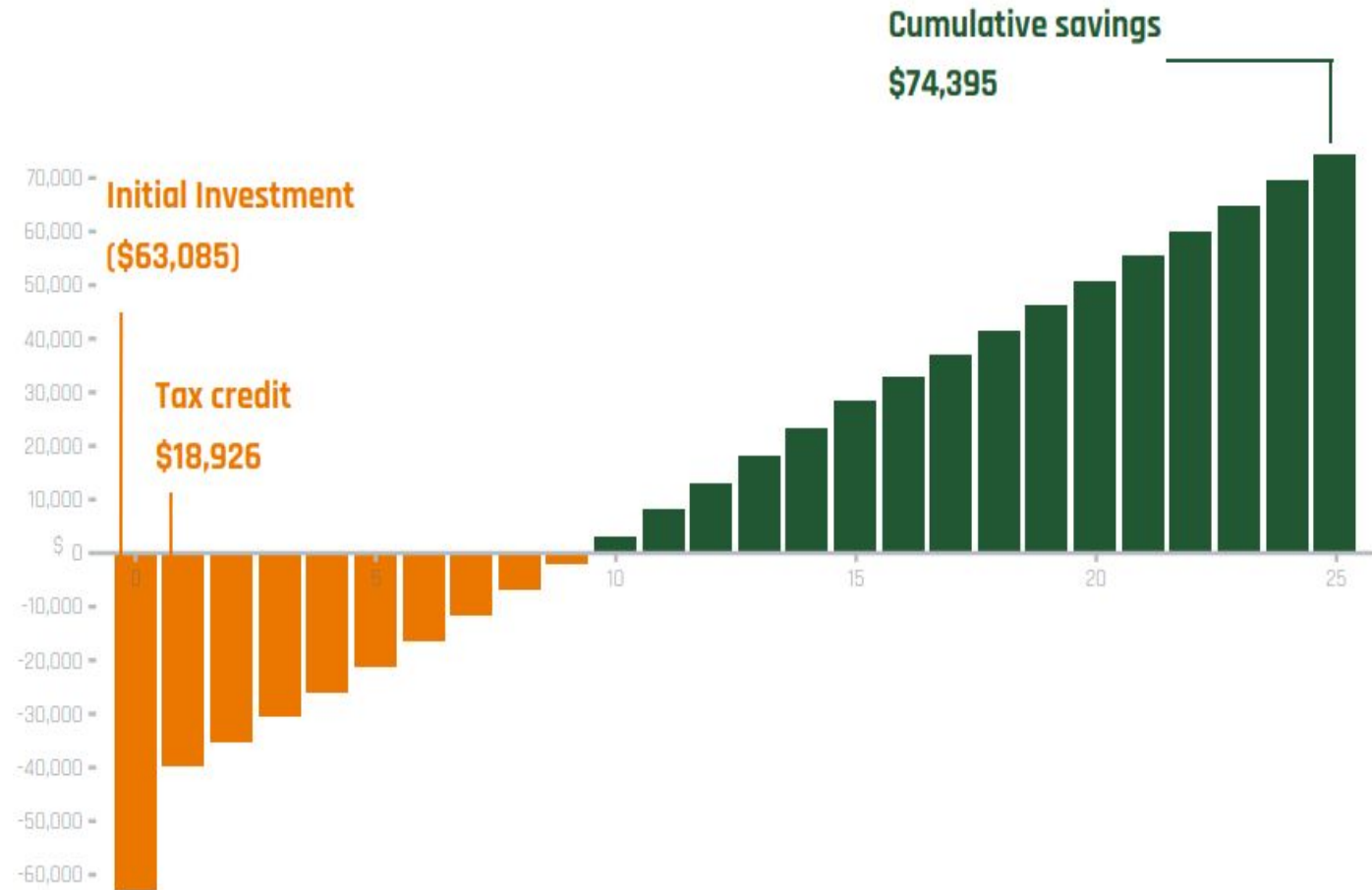

Solar Design

Every home solar system should be custom-designed to match the unique characteristics of the home and the goals of the homeowner.



Solar Design cont.

- 3D model is created from aerial and / or LIDAR imagery
- Roof orientation and pitch provide the basis for sunlight availability (south is best, east and west are good)
- Shading from roof obstructions, trees, or other structures is modeled
- Roof access / fire setbacks are set
- Other factors are incorporated (HOA requirements)
- Solar panels are placed in the best locations
- An energy generation model is created from the sunlight model + specifications from the panels, inverters and a dozen other factors
- *NOTE: A site evaluation should be completed to validate the property conditions in the model*

Shade
from
chimney
& trees

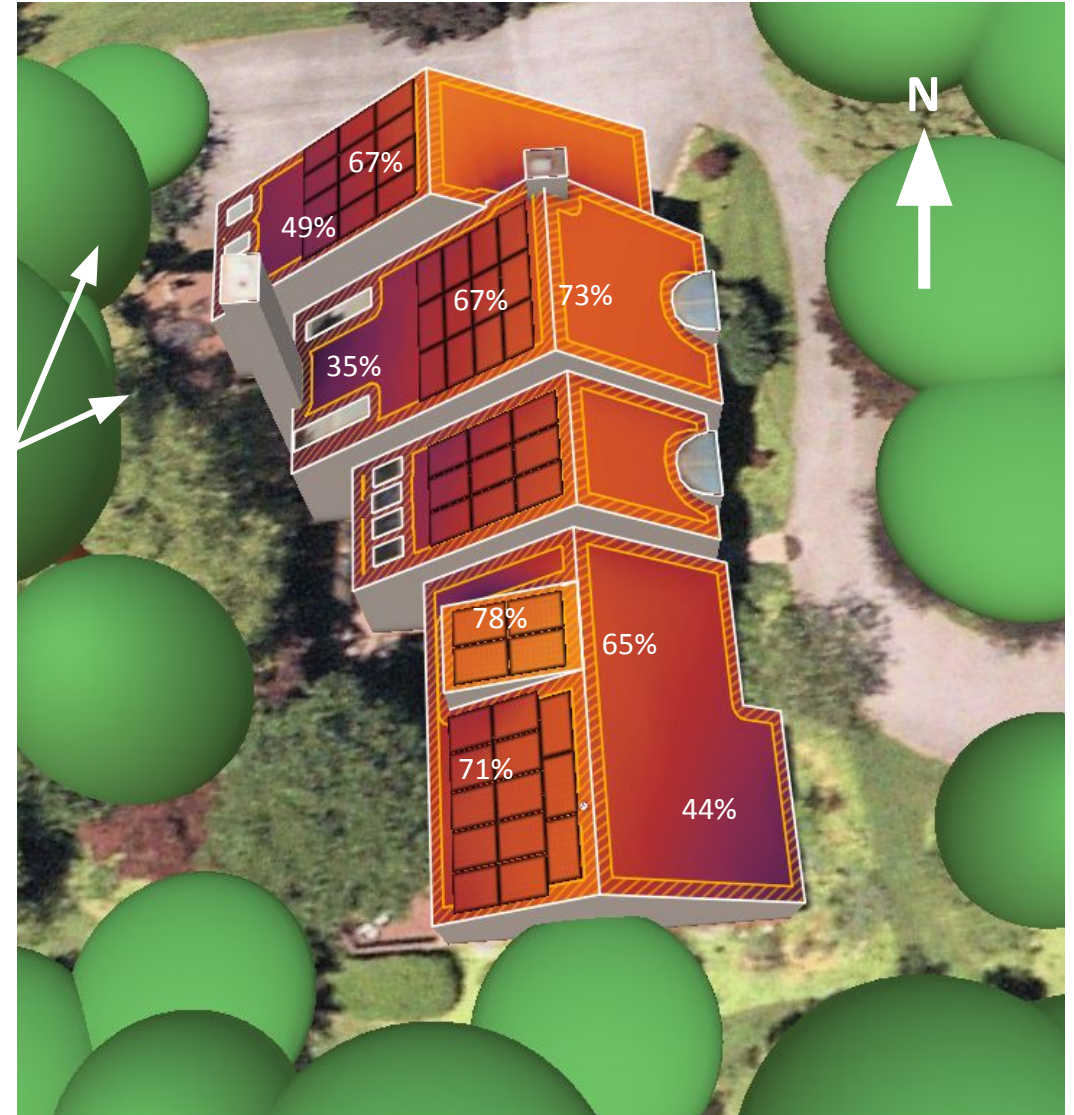

Modeling Reminder

Just like any model...

Garbage in = Garbage out

Solar projections depend on dozens of variables.
Make sure you're working with a reputable contractor or compare multiple quotes.

And don't hesitate to ask: *What assumptions are being used in your model?*

Solar Costs and Benefits – Example 1

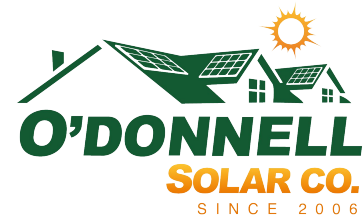

Average irradiance	65%
Number of panels	50
Generating capacity	20kW DC
Electricity generated	111%
Investment	\$65k
Federal tax credit	\$19.5k
Net investment	\$45.5k
Cost of electricity (solar vs. PECO)	\$0.09/kWh vs \$0.18/kWh
Lifetime savings	\$48k
Payback	12 yrs
Warranted lifetime	25 yrs
IRR	6.3%

Solar Costs and Benefits - Example 2

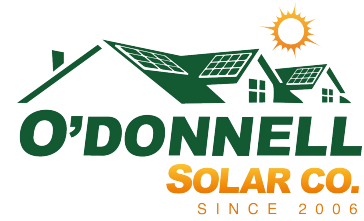

	More sun	Original
Average irradiance	76% ↑	65%
Number of panels	42 ↓	50
Generating capacity	16.8kW DC ↓	20kW DC
Electricity generated	115% ↑	111%
Investment	\$54k ↓	\$65k
Federal tax credit	\$16.2k	\$19.5k
Net investment	\$37.8k ↓	\$45.5k
Cost of solar electricity	\$0.05/kWh ↓	\$0.09/kWh
PECO cost	\$0.18/kWh	
Lifetime savings	\$58k ↑	\$48k
Payback	10 yrs ↓	12 yrs
Warranted lifetime	25 yrs	
IRR	8.5% ↑	6.3%

Aesthetics of Solar Systems

No more blue (polycrystalline) cells, silver frames and white backsheets...



Aesthetics of Solar Systems cont.

- Residential panels come in standard all-black construction
- Black mounting hardware is readily available and commonly used
- Accessories such as front trim skirts are also available
- Wiring can be hidden in attic spaces if available
- Exterior conduit where necessary can either be painted to match roofing or siding*

**NOTE: Other solar-related electrical equipment such as AC disconnects can not be painted.*



Aesthetics of Solar Systems – Design Considerations

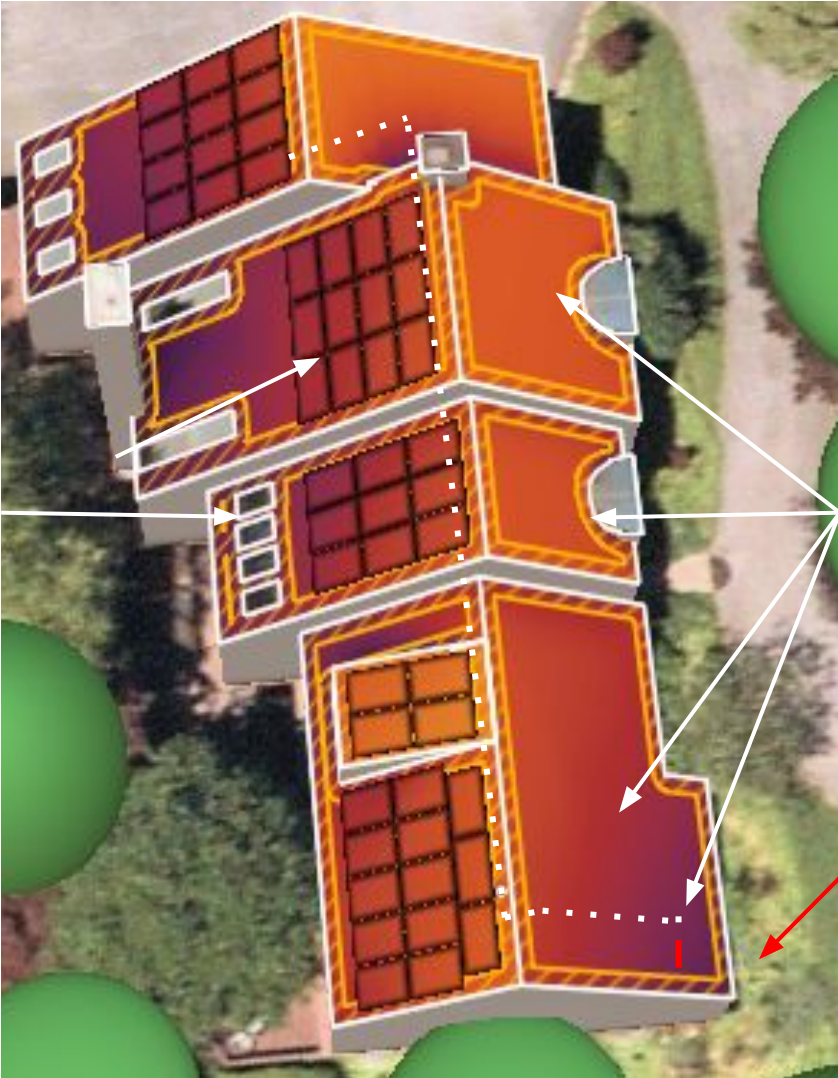

Rectangular arrays centered on roof planes

Wiring & conduit in attic

External wiring & conduit painted to match siding

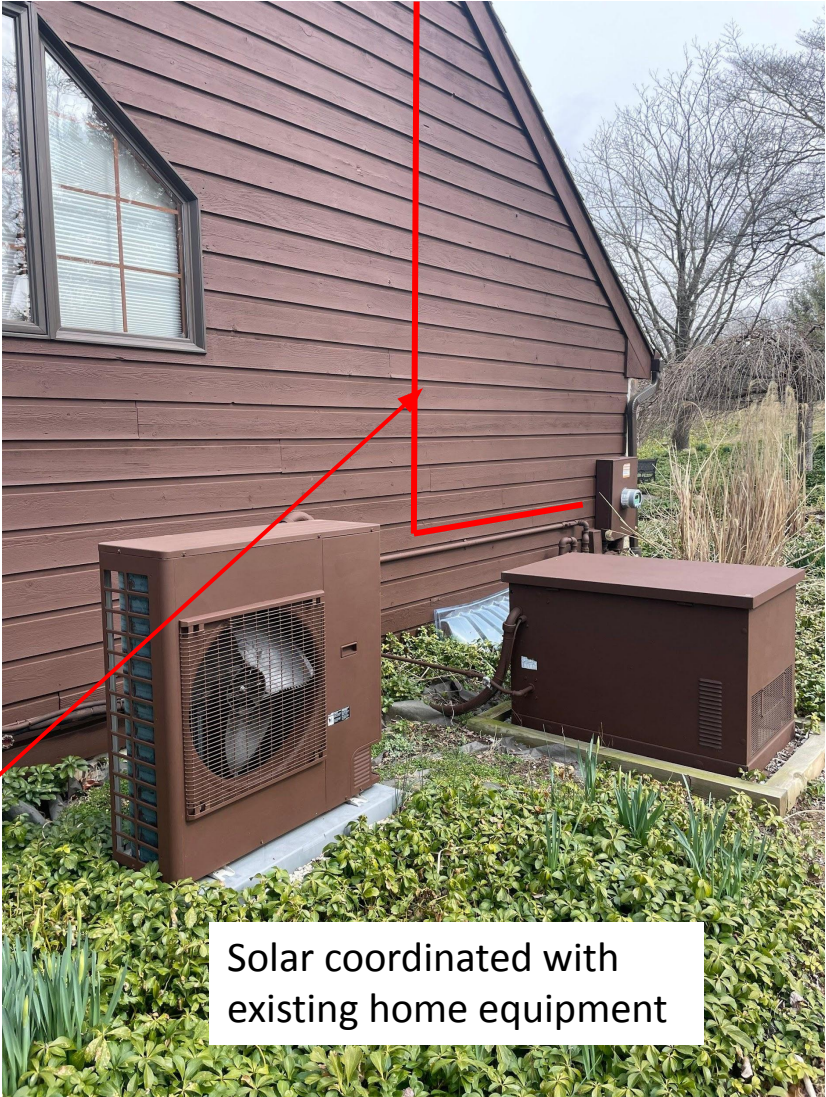

Solar coordinated with existing home equipment

Your Roof: The Foundation of Solar

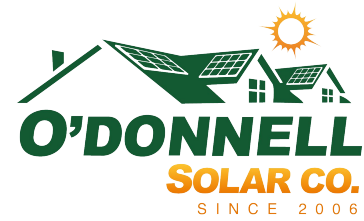

- It's critical that:
 - Your roof is in good shape prior to installing solar
 - Both structurally and as a roofing / waterproofing system
 - Highly don't recommend to put solar on an old roof
 - Proper attachment flashing products and methods are used to waterproof attachment points that go through your roof
 - Different attachment products and flashing methods are used for different roof types
 - Care is taken to avoid damaging the roof during the course of installation
 - Foot traffic, dropping tools or equipment, inserting flashing between courses of roofing, etc.

Safe Installation

- Solar modules must be tested and UL listed to UL61730
- Solar inverters must be tested and listed to UL1741 including ground & arc fault protection
- Solar mounting system must be tested and listed to UL2703 (mechanical + electrical grounding & bonding)
- Subcomponents must be tested and listed to various standards including connectors listed to UL6703
- Solar installations must comply with NFPA 70 (the National Electric Code) and must be inspected

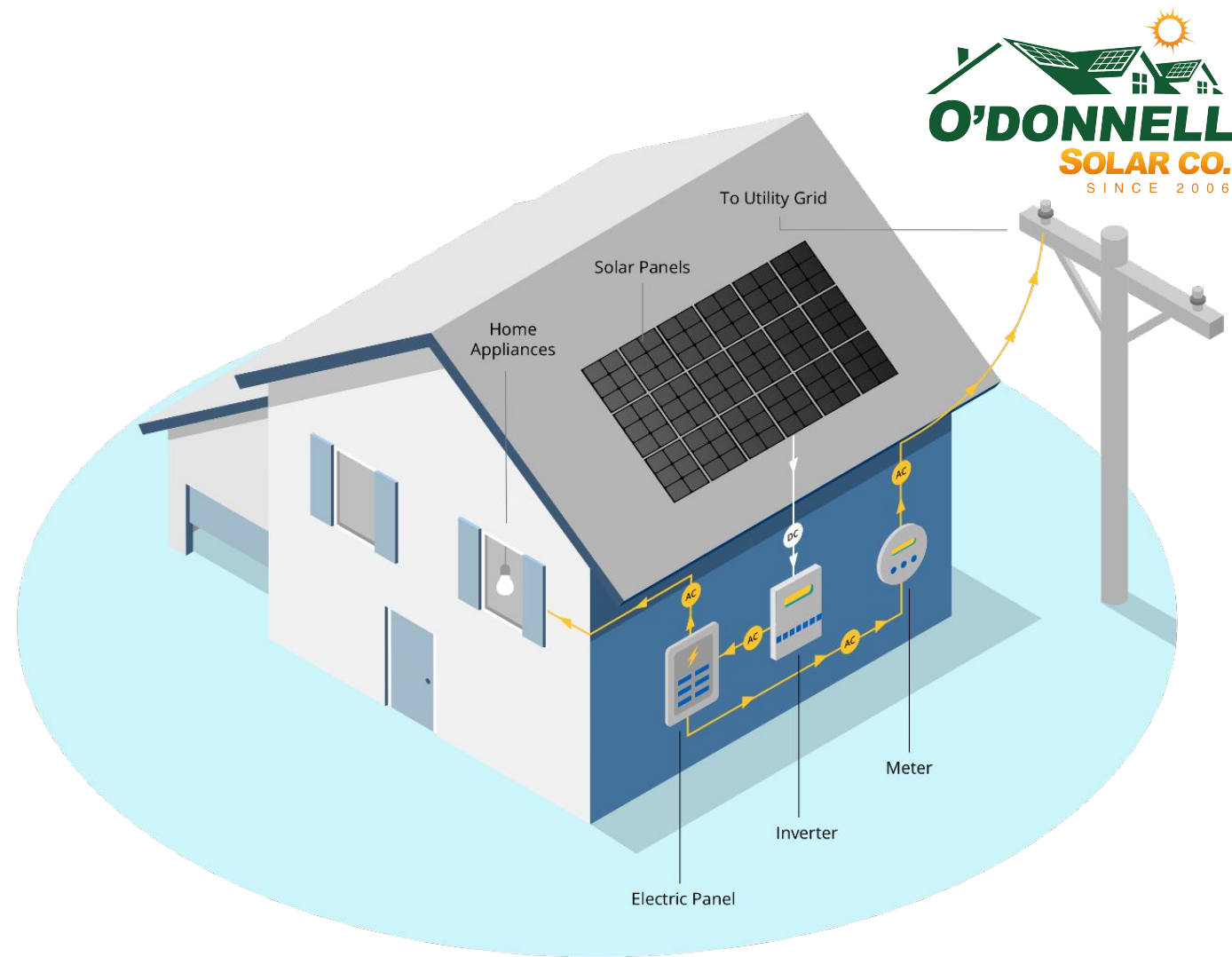

The bottom line:

Solar systems and equipment are just as safe as any other piece of electrical equipment in your home.

But it's important to remember that there are no user-serviceable parts in your solar equipment.

Safety: Wind & Snow Loads

- Solar panels and mounting systems are tested extensively and rated for installation in every area of the country including Miami-Dade and Broward counties.
- Almost all roofs are built to handle the additional ~3psf from a solar array BUT...
- A survey of the roof structure should always be conducted by the contractor
- Many (but not all) townships require plans stamped by a PE

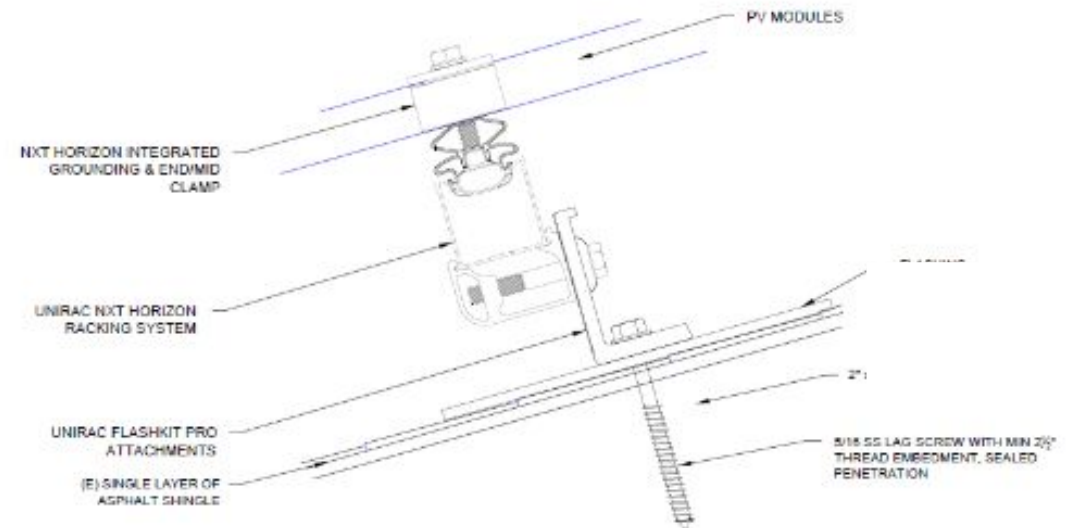
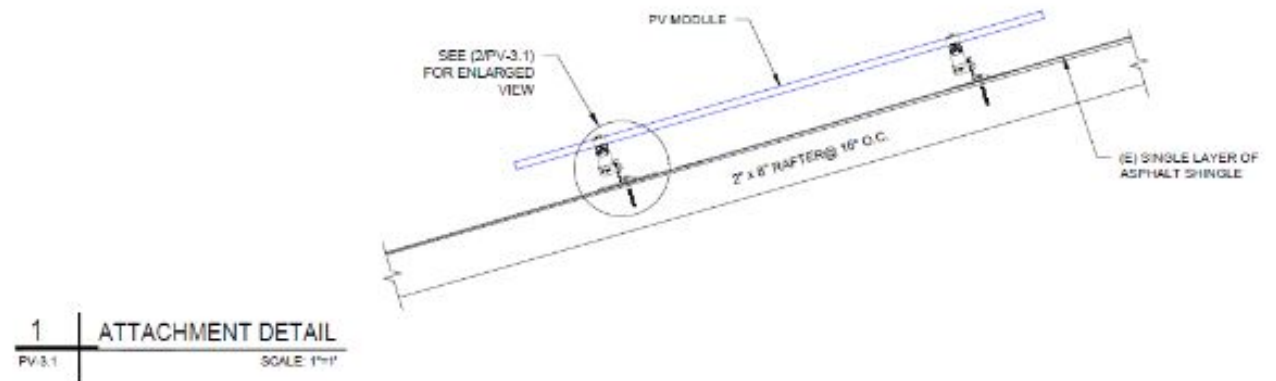

Example Planset

Mounting conditions

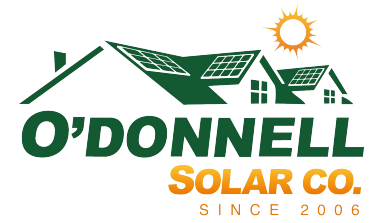

	# MODULES PER ARRAY	ROOF TYPE	ATTACHMENT	ROOF HEIGHT	FRAME MATERIAL	FRAME TYPE	FRAME SIZE	OC SPACING
AR-01	24	ASPHALT SHINGLE	UNIRAC FLASHKIT PRO	TWO STORY	WOOD	ENGINEERED TRUSS	2" x 4"	24"

Local conditions from IRC wind and snow load maps

DESIGN CRITERIA

MODULES:
24
MAX DISTRIBUTED LOAD: 3 PSF
SNOW LOAD: 25 PSF
WIND SPEED:
115 MPH 3-SEC GUST.
LAG SCREWS:
5/16" x 2.5" MIN EMBEDMENT
NOTE:
INSTALLERS TO VERIFY RAFTER SIZE, SPACING AND SLOPED SPANS, AND NOTIFY E.O.R. OF ANY DISCREPANCIES BEFORE PROCEEDING.

Attachment spacing and placement

Solar array load calculations

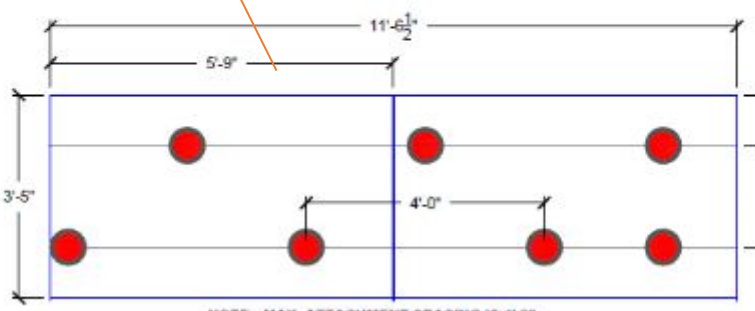
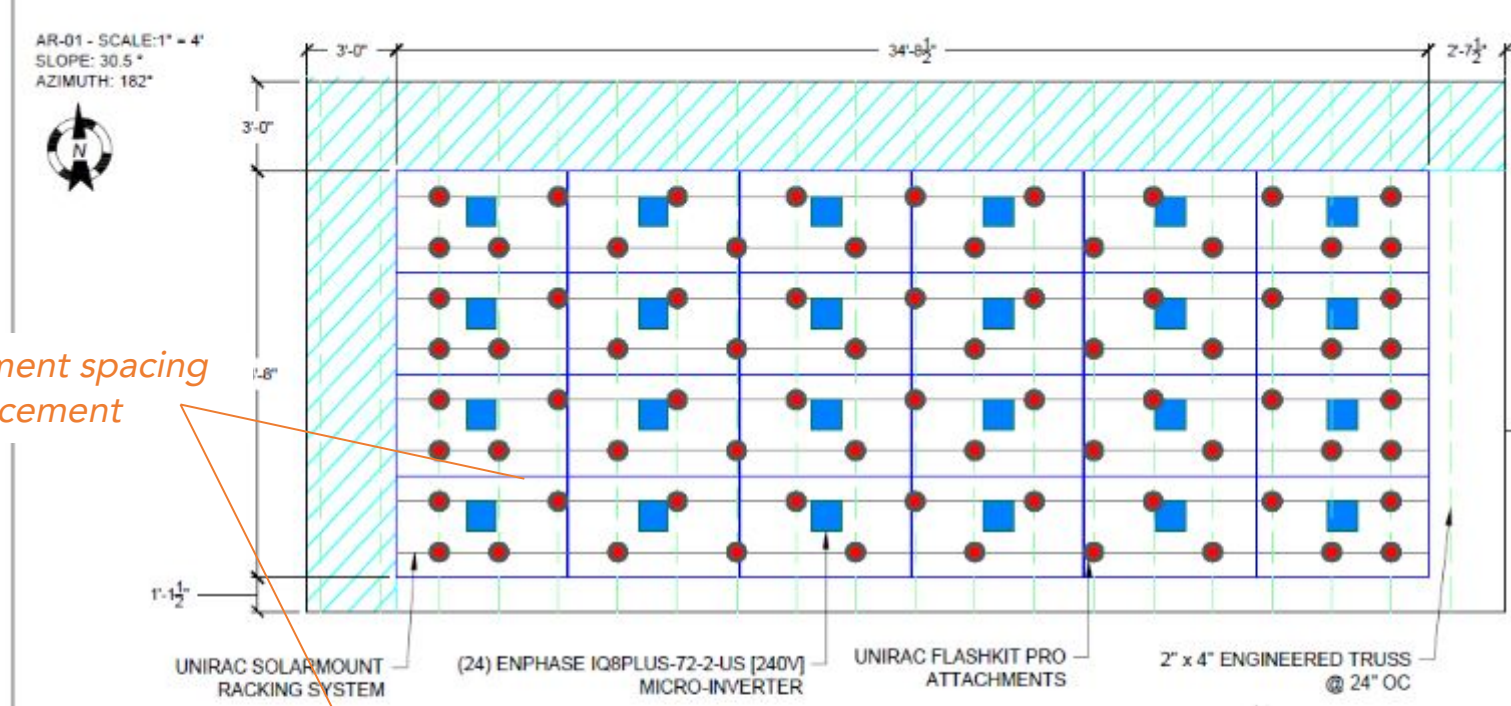

Firm License Number: 002464
 VSE Project Number: U5035.0002.221

Vector Structural Engineering has reviewed the existing structure with loading from the solar array and screw connections to the existing framing. The design of the racking system, racking connectors, and all other structural is by others. Use, service, maintenance, and all other nonstructural aspects of the design are by others. Electrical is by others, unless stamped by Dean Leverone.

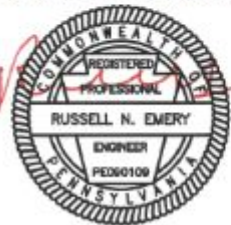

06/13/2022

VECTOR ENGINEERS

POINT LOAD CALCULATION PER ARRAY

ITEM	#OR	WEIGHT PER (lbs)	TOTAL WEIGHT (lbs)
MODULES	24	45.19	1084.56
RAILS	235.20	0.4	102.5
ATTACHMENTS	76	0.65	49.40
TILT LEGS	0	3.5	0
MICRO-INVERTERS	24	2.4	57.6
TOTAL WEIGHT			1294.1 lbs
MODULE DIMENSION (LxW)	69.09" x 40.86"		19.60 sq.ft.
WEIGHT PER MOUNT	1294.1 / 76 =		17.0 lbs/Mount
WEIGHT PER SQ FT	1294.1 / 470.40 sq.ft. =		2.8 lbs/sq.ft.

O'DONNELL SOLAR CO.

CONTRACTOR INSTALLED

O'DONNELL ROOFING CO
 CHRIS FISHER
 311 LENOX RD.
 HAVERTOWN, PA 19083
 License No: PAHIC#006425
 Phone: (914) 806-8946
 Email: chrisfisher@odonnellsolar.com

DETAIL LAYOUT

PV 3.0

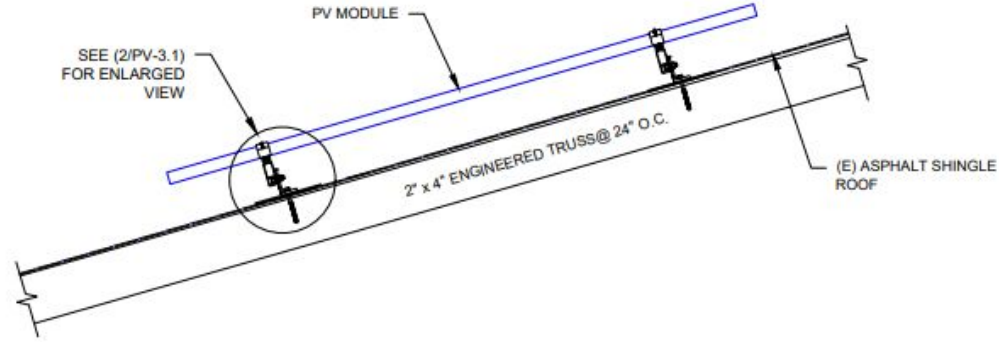

1 ATTACHMENT DETAIL
PV-3.1 SCALE: 1"=1'

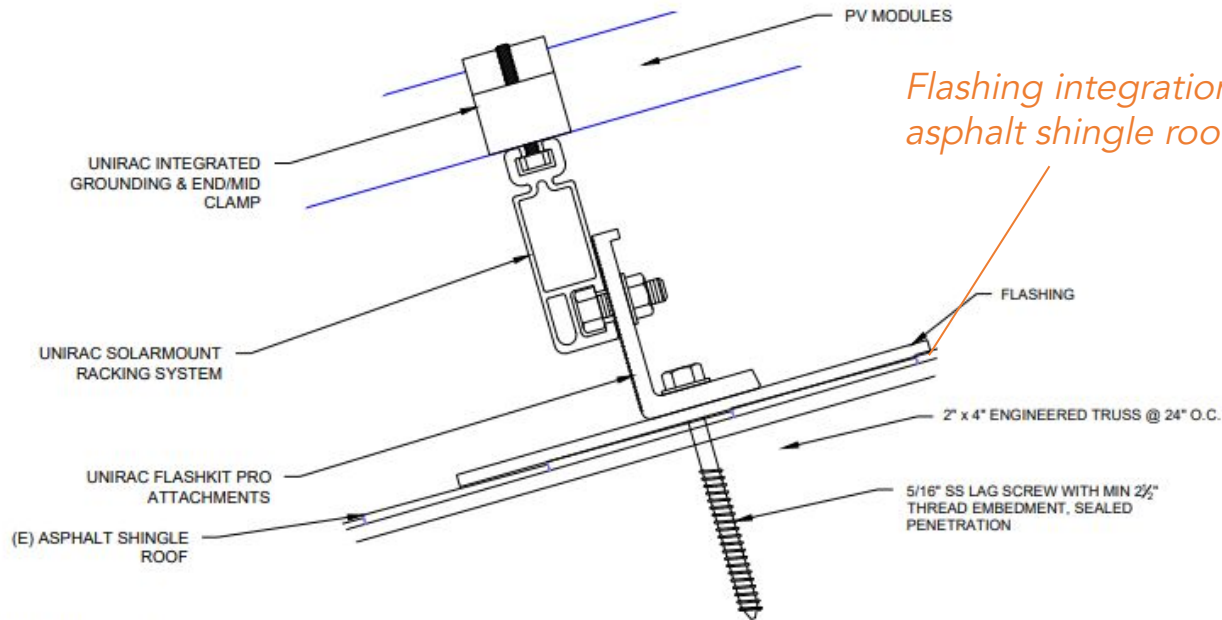

2 ATTACHMENT DETAIL (section view)
PV-3.1 SCALE: NTS

VECTOR
ENGINEERS

851 N. GALEN PARK BLVD. STE. 100 PHONE (801) 990-7735
DRAPER, UTAH 84020 WWW.VECTORENG.COM



08/30/2023
Firm License Number: 002464
VSE Project Number: U5035.0002.221

Vector Structural Engineering has reviewed the existing structure with loading from the solar array and screw connections to the existing framing. The design of the racking system, racking connections, and all other structural is by others. Mechanical, architectural, and all other nonstructural aspects of the design are by others. Electrical is by others, unless stamped by Dean Liverson.



CONTRACTOR INSTALLED

O'DONNELL SOLAR CO
CHRIS FISHER
137 MEDIA LINE RD
BROOMALL, PA 19008
License No: PAHIC#180844
Phone: (914) 806-6946
Email: chrisfisher@odonnellsolar.com

1
2
C
F
R
D
A

MOUNTING LAYOUT

PV 3.1

Home Solar Maintenance

- No regular maintenance is required
- Normal rainfall will wash off dust and “clean” the panels
 - *NOTE: Unusual circumstances, such as nearby construction may benefit from cleaning*
- Solar panels and (most) inverters contain no moving parts
- Light amounts of snow (~2”) will usually melt off of the panels with a few hours of sun
- Heavier amounts of snow may take longer
 - *Note: It’s important to consider the use of snow guards or snow fences when solar arrays are over regularly used entry and egress points*
- Most important is for the initial installation to be performed correctly using good quality materials and workmanship
- Next most important is to monitor your system through the inverter’s app or a webpage
 - *NOTE: Notifications can be set up for system errors, under performance or just regular periodic energy generation reporting*
 - *NOTE: System production can vary by 5-10% on an annual basis due to weather patterns. Over the 25-year system lifetime, these variations should coalesce around a mean.*

Home Battery Design

- Every battery system should be tailored to the unique needs of each home and homeowner.
- From daily energy consumption to outage protection and future goals, the design should reflect how the homeowner actually lives and uses power.

HOUSEHOLD WITH SOLAR, PLUS BATTERIES

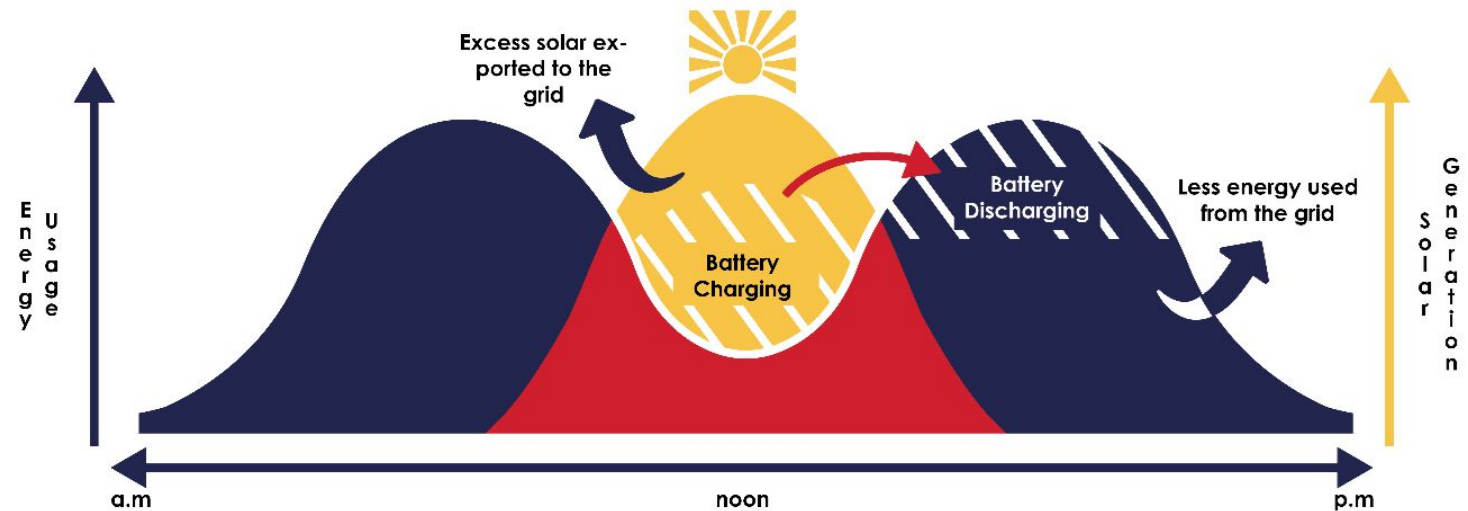

What are Home Batteries?

Tesla Powerwall



Enphase IQ Battery



- Fundamentally they are packs of the same lithium ion cells as EVs use
- They include management systems that:
 - Integrate your power sources (solar, batteries, grid and generators)
 - Monitor how much energy your home is consuming
 - Decide how best to power your home within the protocols that you program them with
- Integration of EVs and bidirectional charging (V2H, V2G, V2X) coming soon...
- Nearly all battery systems are virtual power plant (VPP) ready and can provide grid services
 - NOTE: VPPs and grid services are not allowed by PA yet

Home Batteries

Can be used in several different ways:

- Emergency backup
 - Same as a generator
- Self-sufficiency
 - Store solar energy during the day to use at night
- Arbitrage
 - Store solar energy to use during peak electricity pricing
 - *NOTE: PECO has time of use rates, but you must opt in*

Home batteries may be switched or automatically switch between different uses

Home Battery Design Considerations

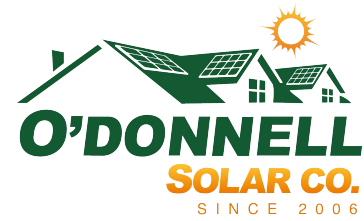

- Starts with primary use case (emergency backup, self-sufficiency or arbitrage)
 - Each will have different implications for battery capacity
- Considers energy use vs. energy generation
 - Self-sufficiency looks at daytime loads vs. nighttime loads
 - Energy arbitrage looks at loads during peak pricing house vs. off-peak
- Emergency backup design has additional factors
 - Length of time you'd like to power your home + loads to be powered (whole home vs. critical loads)
 - Critical design months are typically winter with low solar production vs. home loads
 - Homes with electric heat or heat pumps use a lot of electricity in the winter vs. homes with natural gas or other heating
 - We assume the worst case of no solar contribution for the critical design months, particularly in the winter
- Battery prices are still quite high
 - But on a trajectory similar to where solar was ~10 yrs ago (ie. on a fairly steep downward trajectory, external forces like tariffs notwithstanding)
 - 1-2 days of emergency backup starts around \$30k

Solar 101: Next Steps

- 1) Do research on installers
 - Reputable, licensed and insured
- 2) Get multiple quotes
 - Review the scopes & designs in detail as they will vary
- 3) Beware of offers that sound too good to be true
 - They usually are
- 4) Use local resources
 - Friends & neighbors
 - Marple library
 - Local townships
 - Sustainability councils



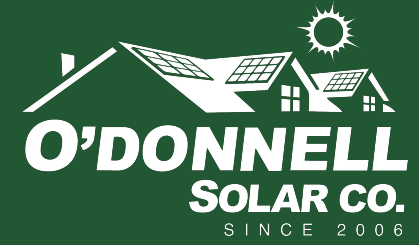

Thank you!